

SCXI™-1314 TERMINAL BLOCK

Introduction

This document contains information and step-by-step instructions for verifying the value of the shunt-calibration resistors, the value of the quarter-bridge resistors, and the performance of the temperature sensor on the National Instruments SCXI-1314 terminal block.

What Is Calibration?

Calibration consists of determining the measurement accuracy of a device and correcting for the measurement error. For SCXI-1314 terminal blocks, calibration is simply determining the measurement accuracy of the components on the terminal block. Because these components are not user-adjustable, calibration consists of a verification procedure only.

Why Should You Calibrate?

Electronic components drift with time and temperature, which could invalidate the factory-set specifications of the device. Calibration ensures your SCXI-1314 terminal block still meets National Instruments standards for accuracy. If the results of the verification procedure indicate that your terminal block is out of specification, contact National Instruments for a replacement component.

How Often Should You Calibrate?

The measurement accuracy requirements of your application determine how often you should calibrate your SCXI-1314 terminal block. National Instruments recommends you verify your terminal block at least once every year. You can shorten this interval to six months or 90 days, based on the demands of your application.

Equipment and Other Test Requirements

This section describes the equipment, software, documentation, and test conditions required for verifying the operation of your terminal block.

Test Equipment

Verification requires a high-precision voltage source with at least 50 ppm accuracy and a multiranging 5 1/2 digit digital multimeter (DMM) with 15 ppm accuracy. If you will be verifying a temperature sensor, you will also need a thermometer that is accurate to within 0.5 °C.

National Instruments recommends you use the following instruments for verifying your SCXI-1314 terminal block:

- Calibrator—Fluke 5700A
- DMM—NI 4060 or HP 34401A

If these instruments are not available, use the accuracy requirements listed above to select a substitute calibration standard.

Software and Documentation

No software or other documentation is required to verify the operation of the SCXI-1314. You can find all the necessary information in this calibration procedure. However, if you would like more information on the product, refer to the [SCXI-1314 Universal Strain Terminal Block Installation Guide](#).

Test Conditions

Follow these guidelines to optimize the connections and the environment during verification:

- Keep connections to the SCXI-1314 terminal block short. Long cables and wires act as antennae, picking up extra noise that can affect measurements.
- Use shielded copper wire for all cable connections to the device. Use twisted-pair wire to eliminate noise and thermal offsets.
- Keep relative humidity below 80%.
- Maintain a temperature between 15 and 35 °C.

Verification

This section contains step-by-step instructions for verifying the value of the shunt-calibration and quarter-bridge resistors of your SCXI-1314 terminal block. It also contains instructions for verifying the performance of the temperature sensor for those terminal blocks that have a temperature sensor.

Verifying the Value of the Shunt-Calibration Resistors

To verify the value of the shunt-calibration resistors in your SCXI-1314 terminal block, complete the following steps:

1. Open the terminal block enclosure by removing the side cover.
2. Refer to Figure 1 at the end of this document to locate the SCA and SCB resistors on the printed circuit board. SCA and SCB resistors are socketed resistors used for shunt calibration. The SCXI-1314 terminal block comes with a 100 k Ω , 0.1% tolerance resistor installed. However, you can replace this resistor with another one having different resistance or tolerance values. If this resistor is not a 100 k Ω , 0.1% tolerance resistor, modify the formulas in step 4 by replacing the resistance and tolerance values with the corresponding values from your resistor.
3. Using a calibrated DMM, measure the resistance of the SCA for channel 0.
4. Determine if the value of the shunt-calibration resistor meets these specifications:
 - If $100 \text{ k}\Omega - \{0.001 \times 100 \text{ k}\Omega\} \leq \text{SCA} \leq 100 \text{ k}\Omega + \{0.001 \times 100 \text{ k}\Omega\}$, the shunt-calibration resistor value meets its specifications.
 - If $\text{SCA} < 100 \text{ k}\Omega - \{0.001 \times 100 \text{ k}\Omega\}$, the shunt-calibration resistor is out of specification. Contact National Instruments to obtain a replacement resistor.
 - If $\text{SCA} > 100 \text{ k}\Omega + \{0.001 \times 100 \text{ k}\Omega\}$, the shunt-calibration resistor is out of specification. Contact National Instruments to obtain a replacement resistor.
5. Repeat steps 3 and 4 for the remaining shunt-calibration resistors:
 - SCA for channels 1 through 7
 - SCB for channels 0 through 7

You have completed verifying the value of the shunt-calibration resistors on the SCXI-1314 terminal block.

Verifying the Value of the Quarter-Bridge Resistors

To verify the value of the quarter-bridge resistors on your SCXI-1314 terminal block, complete the following steps:

1. Remove the side cover of the terminal block if you have not already done so.
2. Refer to Figure 1 to locate the QTR for channel 0 on the printed circuit board. A QTR is a socketed resistor used for quarter-bridge completion. SCXI-1314 terminal blocks come with a $350\ \Omega$, 0.1% tolerance resistor installed. However, you can replace this resistor with another one having different resistance or tolerance values. If the QTR for channel 0 is not a $350\ \Omega$, 0.1% tolerance resistor, modify the formulas in step 4 by replacing the resistance and tolerance values with the corresponding values from your resistor.
3. Using the 4-wire mode of a calibrated DMM, measure the resistance of the QTR for channel 0.
4. Determine if the value of the quarter-bridge resistor meets these specifications:
 - If $350\ \Omega - \{0.001 \times 350\ \Omega\} \leq \text{QTR} \leq 350\ \Omega + \{0.001 \times 350\ \Omega\}$, the quarter-bridge resistor value meets its specifications.
 - If $\text{QTR} < 350\ \Omega - \{0.001 \times 350\ \Omega\}$, the quarter-bridge resistor is out of specification. Contact National Instruments to obtain a replacement resistor.
 - If $\text{QTR} > 350\ \Omega + \{0.001 \times 350\ \Omega\}$, the quarter-bridge resistor is out of specification. Contact National Instruments to obtain a replacement resistor.
5. Repeat steps 3 and 4 for the QTR resistors for channels 1 through 7.

You have completed verifying the quarter-bridge resistors on the SCXI-1314 terminal block. If your terminal block does not contain a temperature sensor, you have completed all calibration verification procedures for your device. If your terminal block contains a temperature sensor, go on to the next section, [Verifying Temperature Sensor Performance](#).

Verifying Temperature Sensor Performance

If your SCXI-1314 terminal block has Q1 loaded, it contains a temperature sensor. Complete the following steps to verify the performance of the temperature sensor:

1. Connect a +5 VDC power source to the terminal block.
 - a. Hold the terminal block vertically upright and view it from the rear. The terminals on the 96-pin DIN connector are designated as follows for the purposes of this procedure:
 - Column A is on the right, Column B is in the middle, and Column C is on the left.
 - Row 1 is at the bottom and Row 32 is at the top.

Individual pins are identified by their column and row.

For example, “A3” denotes the terminal located in Column A and Row 3. This corresponds to the labeling of the pins on the front connector of a matching SCXI module. It does not necessarily correspond to the labeling of the pins on the rear of the terminal block connector itself, which you can only view by opening the terminal block enclosure.

- b. Strip 0.5 in. of insulation from one end of a 22 AWG solid wire. Insert the stripped end of the wire into terminal **A1** on the 96-pin female DIN connector on the rear of the terminal block. Attach the other end of this wire to the **positive** terminal of the +5 VDC power supply.
 - c. Strip 0.5 in. of insulation from one end of a 22 AWG solid wire. Insert the stripped end of the wire into terminal **A2** on the 96-pin female DIN connector on the rear of the terminal block. Attach the other end of this wire to the **negative** terminal of the +5 VDC power supply.
 2. Connect a calibrated DMM to the temperature-sensor output of the terminal block.
 - a. Strip 0.5 in. of insulation from one end of a 22 AWG solid wire. Insert the stripped end of the wire into terminal **A3** on the 96-pin female DIN connector on the rear of the terminal block. Attach the other end of this wire to the positive input terminal of the calibrated DMM.
 - b. Connect the negative input terminal of the calibrated DMM to the negative terminal of the +5 VDC power supply.
 3. Place the terminal block in a temperature-controlled environment where the temperature is between 15 and 35 °C.

4. When the terminal block temperature equilibrates with its surroundings, measure the temperature sensor output V_{meas} using a calibrated DMM.
5. Measure the actual temperature T_{act} in the temperature-controlled environment using a thermometer calibrated to within 0.5 °C accuracy.
6. Convert V_{meas} (in volts) to measured temperature T_{meas} (in degrees Celsius) by multiplying V_{meas} by 100.
7. Compare T_{act} to T_{meas} .
 - If $(T_{\text{meas}} - 0.9 \text{ °C}) \leq T_{\text{act}} \leq (T_{\text{meas}} + 0.9 \text{ °C})$, the temperature sensor operation has been verified.
 - If $T_{\text{act}} < (T_{\text{meas}} - 0.9 \text{ °C})$, the temperature sensor is nonfunctional. Contact National Instruments for a replacement sensor.
 - If $T_{\text{act}} > (T_{\text{meas}} + 0.9 \text{ °C})$, the temperature sensor is nonfunctional. Contact National Instruments for a replacement sensor.

You have completed verifying the temperature sensor on the SCXI-1314 terminal block.

SCXI-1314 Printed Circuit Board Diagram

The following illustration shows the locations of the SCA and SCB resistors, the quarter-bridge resistors, and channels 0 through 7 of the SCXI-1314 terminal block.

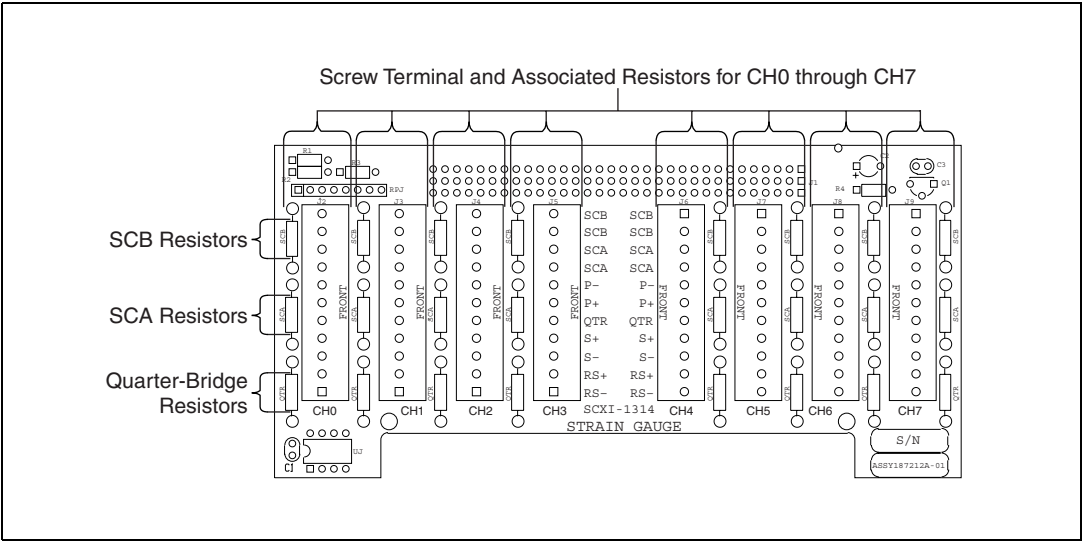

Figure 1. SCXI-1314 Shunt-Calibration Resistors and Quarter-Bridge Resistors